

**FORD:** 1992-1994 TEMPO  
1992-1997 CROWN VICTORIA, ESCORT, MUSTANG, PROBE, TAURUS,  
THUNDERBIRD  
1994-1997 ASPIRE  
1995-1997 CONTOUR  
1992-1997 AEROSTAR, EXPLORER, RANGER  
1994-1996 BRONCO  
1994-1997 ECONOLINE  
1995-1997 F-150, WINDSTAR  
1997 EXPEDITION

**LINCOLN:** 1992-1997 CONTINENTAL, TOWN CAR  
1993-1997 MARK VIII

**MERCURY:** 1991-1994 CAPRI  
1992-1994 TOPAZ  
1992-1997 COUGAR, GRAND MARQUIS, SABLE, TRACER  
1995-1997 MYSTIQUE  
1993-1997 VILLAGER  
1997 MOUNTAINEER

**ISSUE**

The Mass Air Flow (MAF) sensor is not designed to be removed from its body (die-cast or plastic) for servicing. The sensing elements located inside the by-pass tube can be damaged by poking/probing/touching.

**ACTION**

Service the MAF sensor as an assembly (refer to Figure 1).

**WARNING**

**DO NOT DISASSEMBLE THE MAF SENSOR.**

**OTHER APPLICABLE ARTICLES:** NONE

**WARRANTY STATUS:** INFORMATION ONLY

**OASIS CODES:** 203000, 204000, 206000, 607000,  
610000, 610500, 611000, 611500,  
614000, 614500, 698298

**Article No. 96-22-5 Cont'd.**

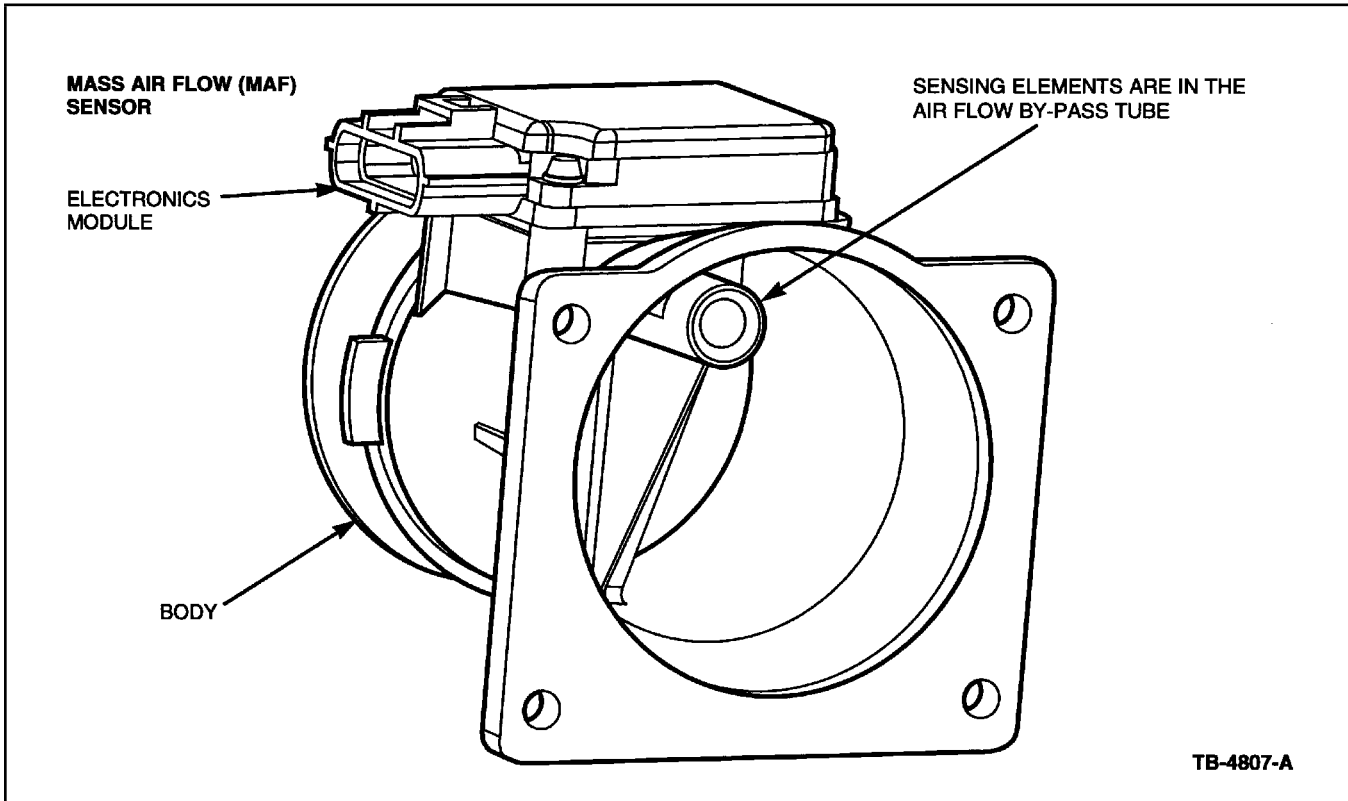

Figure 1 - Article 96-22-5