

GAUGES—TEMPERATURE GAUGE REGISTERS HIGH AND OIL PRESSURE GAUGE REGISTERS LOW DURING NORMAL OPERATING CONDITIONS—VEHICLES BUILT PRIOR TO 7/5/92

**Article No.
93-3-10**

MERCURY: 1991-1992 CAPRI

ISSUE

The temperature gauge may register high and the oil pressure gauge may register low during normal operating conditions. These inaccurate readings are caused by the gauge calibrations.

ACTION

Install a more accurate gauge using the following procedure.

The recalibrated temperature gauge registers midscale at normal operating temperature. The revised graphics of the oil pressure gauge allow for more accurate metering at the low end of the scale, refer to Figure 1. The oil gauge includes a needle stop to prevent off scale (high) reading in cold start conditions.

NOTE

VEHICLES BUILT BEFORE MARCH 1991 HAVE NUMERIC GRAPHICS ON THEIR GAUGES (SEE FIGURE 2) AND THEREFORE, INSTALLATION OF A NEW TEMPERATURE /OIL PRESSURE GAUGE ASSEMBLY WILL ALSO REQUIRE REPLACEMENT OF THE VOLT/FUEL GAUGE ASSEMBLY (FOJY-9305-B) IN ORDER FOR ALL GAUGES TO HAVE MATCHING GRAPHICS. (SEE FIGURE 1). TURBO AND NON-TURBO VEHICLES USE THE SAME TEMPERATURE/OIL AND VOLT/FUEL GAUGES.

SERVICE PROCEDURE

CAUTION

TO ENSURE PROPER OPERATION OF THE GAUGE, REPLACEMENT SHOULD BE PERFORMED IN A DUST FREE ENVIRONMENT. ALWAYS WEAR GLOVES TO PREVENT PUTTING FINGER PRINTS ON THE INSTRUMENT CLUSTER.

REMOVAL - TEMPERATURE/OIL PRESSURE GAUGE ASSEMBLY:

1. Remove the instrument cluster as outlined on page 13-01-9 of the 1992 Capri Service Manual.
2. Push down the eight (8) clips located at the top and bottom of the instrument cluster, remove the front cover from the housing.
3. Remove the six (6) screws from the backside of the housing which attach the Temperature/Oil pressure gauge assembly.
4. Slightly lift the front facia of the speedometer and remove the Temperature/Oil pressure gauge assembly.

INSTALLATION - TEMPERATURE/OIL PRESSURE GAUGE ASSEMBLY:

1. Place the instrument cluster upside down, refer to Figure 3.

NOTE

CLEARANCE BETWEEN THE CIRCUIT BOARD AND THE INSTRUMENT CLUSTER HOUSING CAN BE MAINTAINED BY POSITIONING THE INSTRUMENT CLUSTER UPSIDE DOWN.

2. Position the Temperature/Oil gauge assembly (F3JY-10883-A) into the instrument cluster housing and attach with six (6) screws. Tighten in the order shown in Figure 4.
3. Ensure that there is clearance between the circuit board and the instrument cluster housing lower face, refer to Figure 5.

NOTE

CLEARANCE CAN BE CONFIRMED BY INSERTING PAPER BETWEEN THE TEMPERATURE/OIL PRESSURE GAUGE CIRCUIT BOARD AND THE HOUSING, ENSURING THAT THE PAPER CAN BE SMOOTHLY INSERTED.

Article No. 93-3-10 Cont'd.

- Attach the front cover to the instrument housing with the eight (8) clips.
- Install the instrument cluster as outlined on page 13-01-9 of the 1992 Capri Service Manual.

NOTE

VEHICLES BUILT BEFORE MARCH 1991 HAVE NUMERIC GRAPHS ON THEIR GAUGES. THEREFORE, INSTALLATION OF A NEW TEMPERATURE /OIL PRESSURE GAUGE ASSEMBLY WILL ALSO REQUIRE REPLACEMENT OF THE VOLT/FUEL GAUGE ASSEMBLY IN ORDER FOR ALL GAUGES TO HAVE MATCHING GRAPHICS.

| PART NUMBER | PART NAME |
|--------------|---|
| F3JY-10883-A | Temperature/Oil Pressure Gauge Assembly |
| FOJY-9305-B | Volt/Fuel Gauge |

OTHER APPLICABLE ARTICLES: NONE
WARRANTY STATUS: Eligible Under Basic Warranty Coverage For 1991 Models And Bumper To Bumper Warranty Coverage For 1992 Models

| OPERATION | DESCRIPTION | TIME |
|-----------|---|---------|
| 930310A | Replace - Temperature, Oil Pressure Gauge Assembly | 1.2 Hr. |
| 930310B | Replace - Temperature, Oil Pressure Gauge Assembly And Volt, Fuel Gauge On Vehicles Built Prior To March 1991 | 1.4 Hr. |

DEALER CODING

BASIC PART NO.
10883
OASIS CODES: 204000, 204200

CONDITION CODE
79

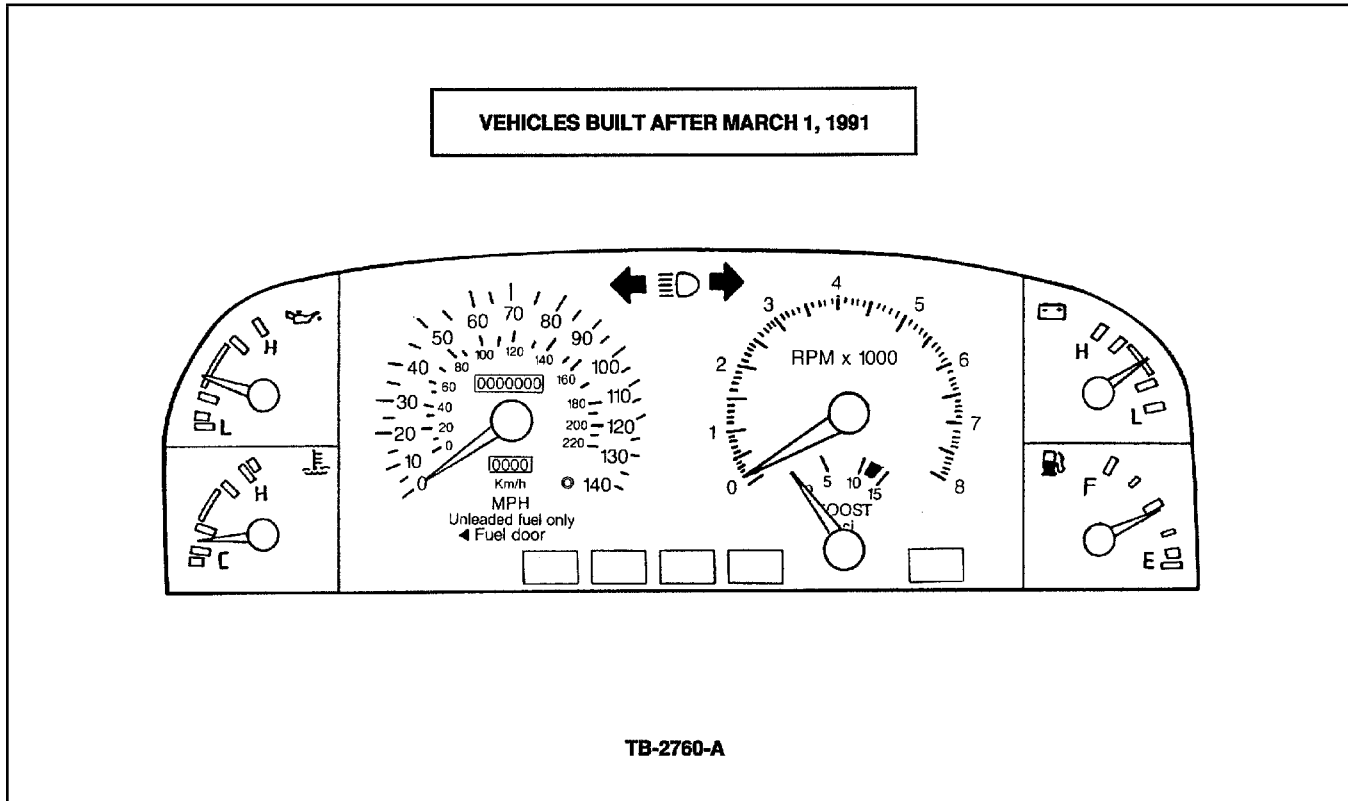

Figure 1 - Article 93-3-10

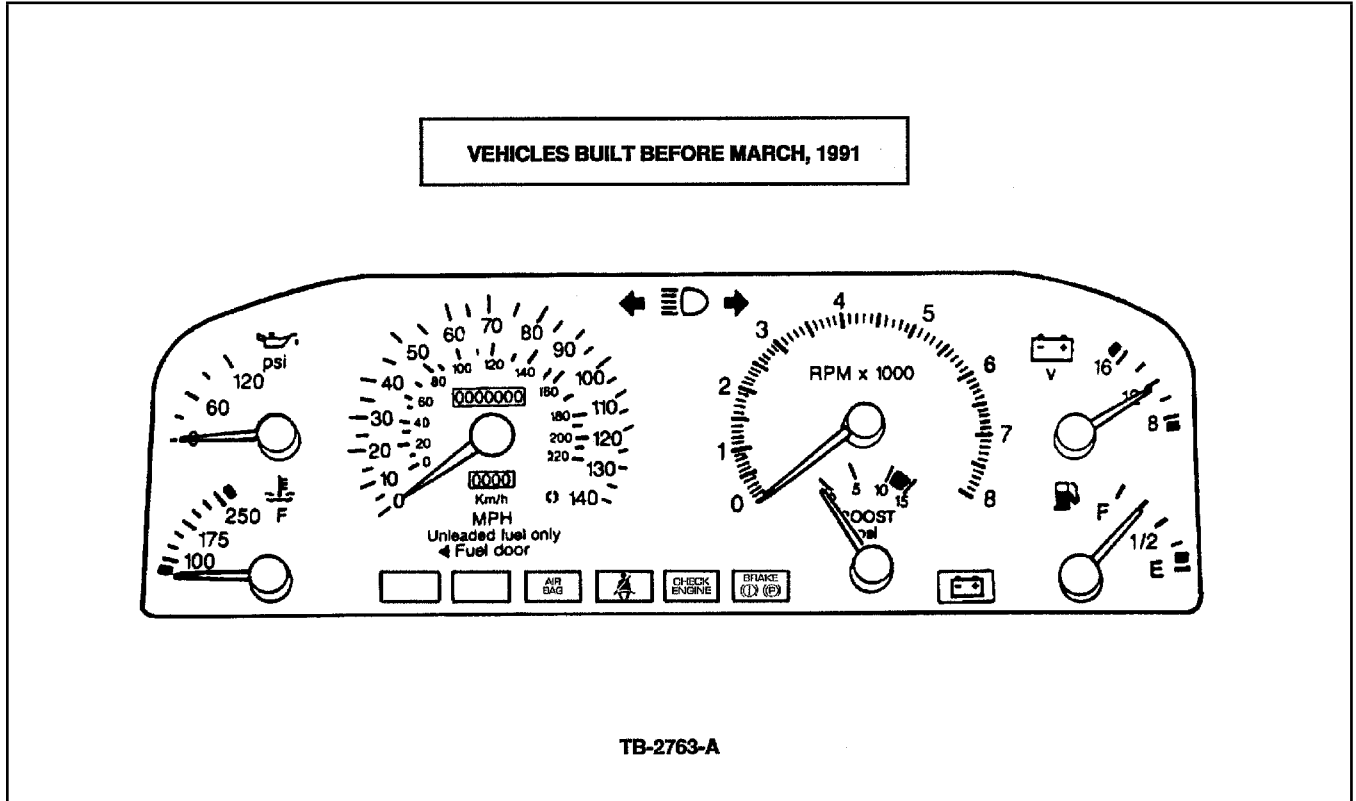

Figure 2 - Article 93-3-10

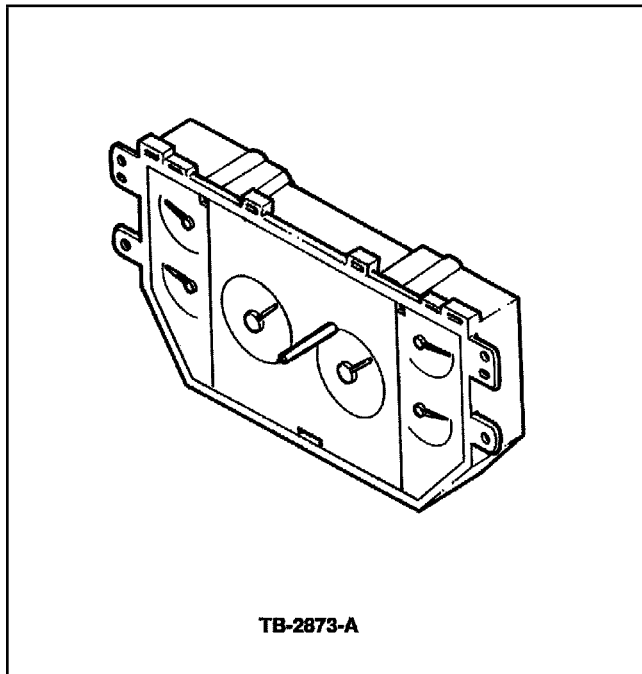
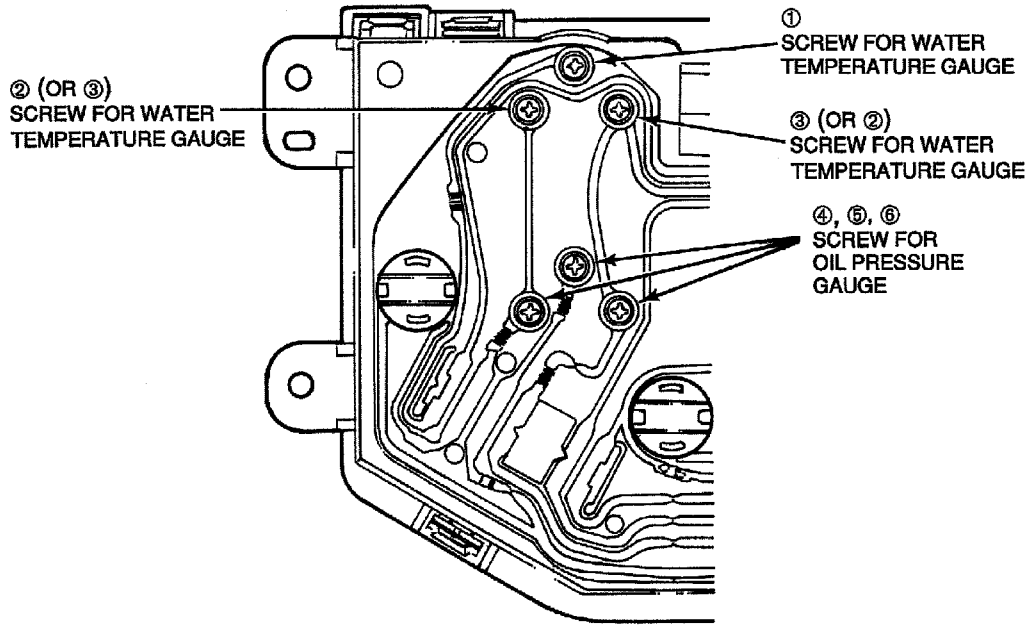

Figure 3 - Article 93-3-10

Article No. 93-3-10 Cont'd.



TB-2874-A

Figure 4 - Article 93-3-10

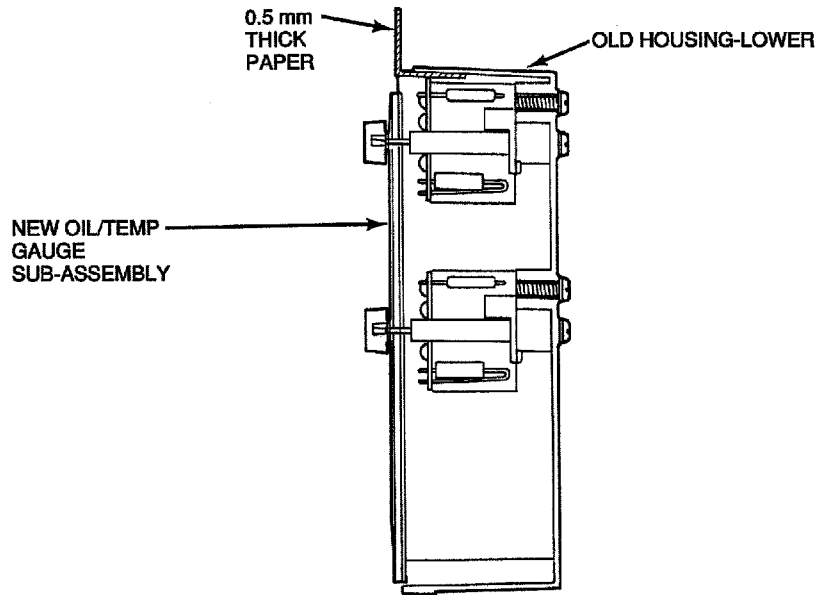

TB-2875-A

Figure 5 - Article 93-3-10