

- **AIR CONDITIONING—DEALER INSTALLED—FAN POWER LEAD WIRE “RELOCATION”**
- **FAN—AIR CONDITIONING—DEALER INSTALLED—RELOCATION OF POWER LEAD WIRE**
- **WIRING—AIR CONDITIONING—DEALER INSTALLED—PUSHER FAN POWER LEAD “RELOCATION”**

**Article No.
91-24-9**

MERCURY: 1991 CAPRI

ISSUE

Dealer installed air conditioning kits purchased before 5/31/91 contained pusher fans with the power lead in the 1 o'clock position. In this position the fan motor may fill with water.

ACTION

Relocation of the power lead to the 7 o'clock position will be necessary to ensure that the fan motor will not fill with water. Relocation can be obtained by removing and repositioning the fan or by replacing the fan with a new fan with the wires in the 7 o'clock position. Refer to the following procedure for service details.

SERVICE PROCEDURE: FOR KITS NOT INSTALLED

1. Cut the cable tie holding the fan motor leads in place and discard the cable tie.
2. Remove the (2) bolts securing the motor to the fan shroud.
3. Rotate the motor 180 degrees so that the leads are in the 7 o'clock position. Refer to Figure 1.
4. Replace the (2) bolts securing the motor to the fan.
5. Manually spin the fan blades to insure that the motor does not contact the shroud.

SERVICE PROCEDURE: FOR KITS ALREADY INSTALLED IN VEHICLES

1. Check the fan operation to determine if replacement is necessary. Disconnect battery terminals.
2. Remove the clip near the passenger side shock tower which holds the liquid line and suction line. Save the clip for reinstallation.

3. Remove the screw securing the liquid line clamp to the passenger side frame rail (near the steering pump). Save the screw for reinstallation.
4. Remove the upper radiator support brackets by removing the (6) bolts securing the brackets. Loosen the bolt holding the support rod from the passenger side front fender to the passenger upper radiation support. Do not remove the bolt. Save the (6) bolts removed from the radiator brackets for reinstallation.
5. Carefully lean the radiator back towards the rear of the vehicle. Remove (2) bolts securing the upper air conditioning condenser mounting brackets to the radiator support. Remove the nut securing the fan upper radiator support. Save the (2) bolts securing the condenser mounting brackets for reinstallation.
6. From below the vehicle's front bumper, gently remove and save the (2) ratcheting rivets (push bolts) which hold the black plastic panel to the lower radiator support. Remove and save the black plastic panel for later reinstallation.
7. Remove the (2) nuts securing the lower fan mounting bracket to the lower radiator support. Save the (2) nuts for reinstallation.
8. From above in the engine compartment unplug the fan and carefully lean the condenser toward the rear of the vehicle. From below the vehicle remove the cooling fan from the radiator support.

NOTE

AS THE CONDENSER IS TILTED BACK MOVE THE FAN BRACKET ASSEMBLY TO THE DRIVER SIDE OF THE VEHICLE TO REMOVE IT FROM BETWEEN THE CONDENSER AND THE

Article No. 91-24-9 Cont'd.

RADIATOR SUPPORT. THIS WILL MINIMIZE THE MOVEMENT ON THE LIQUID LINE BOTTLE JOINT AND PROVIDE MORE SPACE FOR THE FAN TO BE REMOVED.

9. Replace the fan if it is inoperative. If the fan was operational rework the fan by;
 - a. Clipping the cable tie holding the leads to the fan shroud and discard.
 - b. Remove the bolts (2) that hold the fan to the shroud, save the (2) screws for reinstallation.
 - c. Rotate the fan motor 180 degrees so that the motor leads are in the 7 o'clock position, Refer to Figure 1.
 - d. Replace the (2) bolts securing the motor to the shroud.

- e. Plug the fan into the wiring harness and check for proper operation.

10. Reinstall pusher fan to radiator support.
Reinstall the parts removed in steps 2 thru 7.

PART NUMBER	PART NAME
E8GY-19A805-B	Fan-Condenser Auxiliary

WARRANTY STATUS: Eligible Under Basic
Warranty Coverage

OPERATION	DESCRIPTION	TIME
912409A	Fan-Condenser Replace	0.6 Hr.
912409B	Fan-Power Lead - Reroute	0.5 Hr.

DEALER CODING

BASIC PART NO.
19A805

OASIS CODES: 208200, 208300

CONDITION
CODE
43

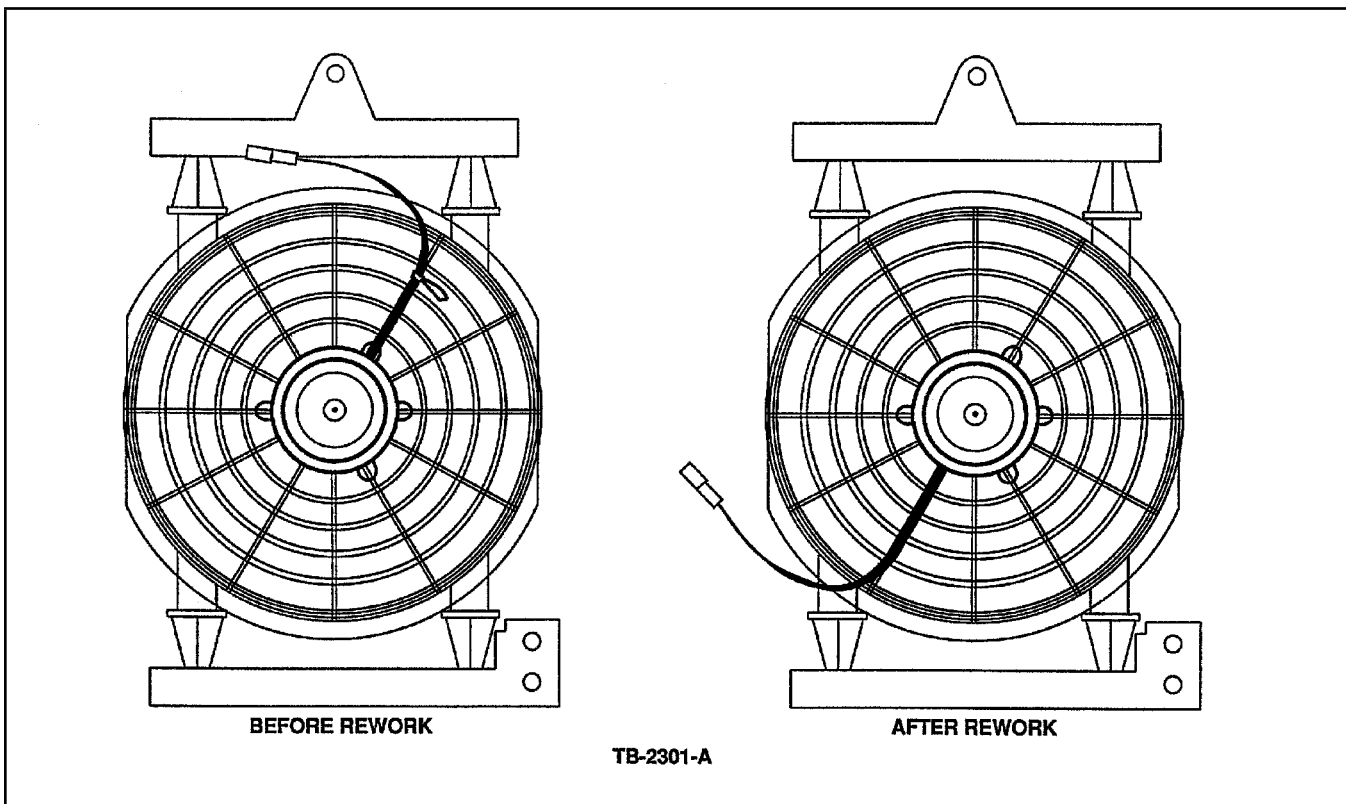

Figure 1 - Article 91-24-9