

**CONVERTIBLE—REAR WINDOW—SCRATCHED BY
THE REAR SEAT BACK LATCH**

**Article No.
91-20-3**

MERCURY: 1991 CAPRI

ISSUE

The rear window may be scratched when lowering the convertible top for stowage. This happens when the rear window passes the rear edge of the rear seat back latch.

ACTION

Install three (3) protectors on the rear edge of the latch to prevent window scratches, Figure 1. Refer to the following procedure for service details.

1. Lower the convertible top to raise the stowage lid and gain access to the seat back latch in the stowage area.

NOTE

DO NOT LOWER THE TOP COMPLETELY INTO THE STOWAGE AREA.

2. Clean the latch with a suitable solvent to remove any grease or foreign material and then dry.
3. Install three (3) protectors, complete with glue, on the rear edge of the latch as shown in Figure 2.

NOTE

STORING THE PROTECTORS IN A WARM AREA WILL AID ADHESION OF THE HOT MELT GLUE.

4. Raise the convertible top.

PART NUMBER	PART NAME
FOJY-76613C78-A	Protectors

OTHER APPLICABLE ARTICLES: NONE
WARRANTY STATUS: Eligible Under Basic
 Warranty Coverage

OPERATION	DESCRIPTION	TIME
912003A	Install Protectors	0.3 Hr.

DEALER CODING

BASIC PART NO.	CONDITION CODE
7052500	70

OASIS CODES: 102000

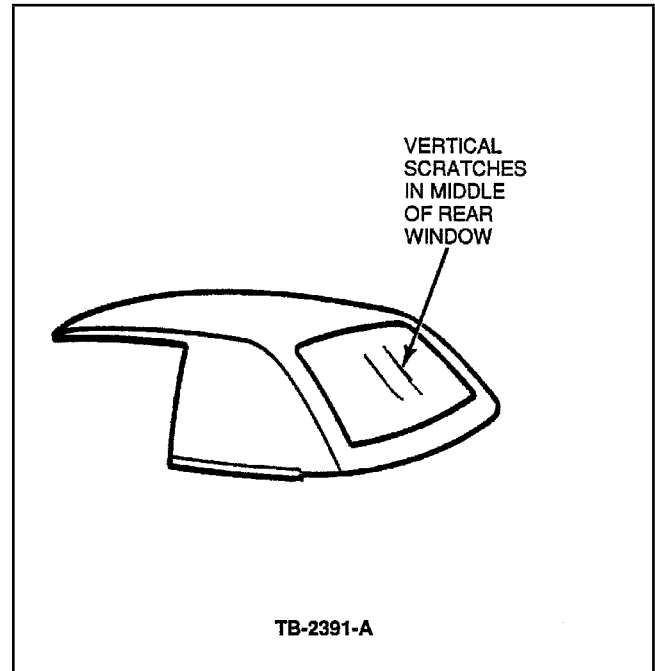

Figure 1 - Article 91-20-3

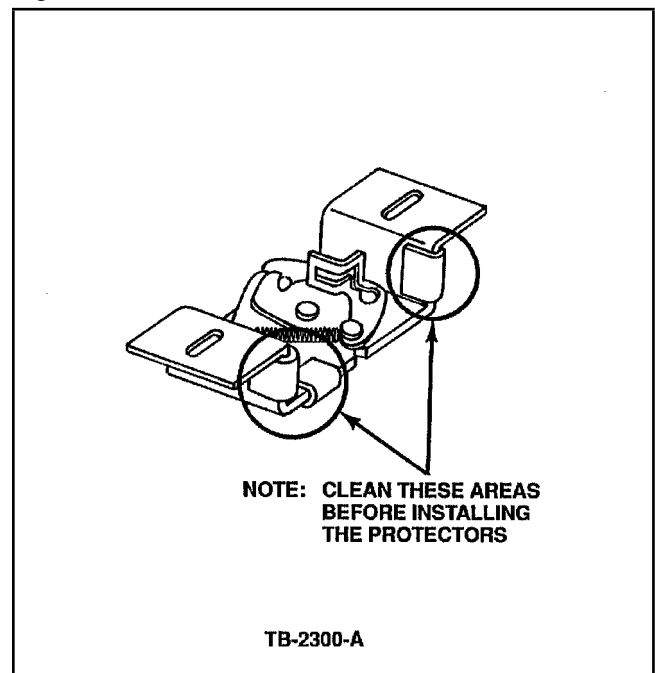

Figure 2 - Article 91-20-3