

MERCURY: 1991 CAPRI**ISSUE**

Fitting and alignment instructions for the accessory hardtop have been developed and are now available for service use.

ACTION

If service is required, refer to the following instructions to ensure correct fit and alignment of the accessory hardtop to the vehicle. Refer to Figure 1 for the hardware kit contents.

CAUTION

INSTALLATION OF THE HARDTOP REQUIRES TWO PEOPLE. DO NOT ATTEMPT TO INSTALL THE HARDTOP ALONE.

NOTE

THE HARDTOP WEIGHS APPROXIMATELY 75 LBS/34 KG.

A. VEHICLE PREPARATION

Water test the vehicle with the convertible top in the up position to verify if the vehicle has any water leaks around the door glass. If any leaks are found around the door glass, follow the procedure in TSB 90-25-7 to correct the leak.

B. HARDTOP FIT

1. Ensure that the convertible top is completely dry before stowing.
2. Lower and carefully stow the convertible top. Leave the sunvisors down and convertible top stowage lid open.
3. Remove the two sliding and one center trim covers concealing the hardtop retaining locations, Figures 4 and 5.
4. Unclip the hardtop electrical wiring loom from the left hand side trim panel in the convertible top storage area and route out past the left hand hardtop retaining location, Figure 2.
5. Close convertible top stowage lid and lock the lid release lever.

6. Using the tool supplied, remove the two retaining bolts from the windshield header, Figure 3.
7. Using an M8 x 1.25 tap, remove the excess paint buildup in the threads of the three hardtop retaining locations, Figures 4 and 5.
8. Fit hardtop locating pins, supplied loose in kit, to the left and right hand side hardtop retaining locations, Figure 6.
9. Remove the left and right hand side hardtop retaining bolts from the hardtop and, using an 8mm allen key, loosen the two locating spacers, Figure 7.
10. With a person at each window opening, using both hands for balance, carefully lift and install the hardtop into position. Ensure that mating holes in windshield header are aligned and locating spacers are positioned over locating pins on the left and right hand sides, Figure 8.
11. Loosely install the two M8 x 45 windshield header hardtop retaining bolts and tooth lock washers (supplied loose in kit). With a person applying downward pressure to the front edge of the hardtop, lightly tighten the windshield header hardtop retaining bolts.
12. Make sure the hardtop is positioned centrally to ensure correct sealing, Figure 8. Then, tighten the locating spacers (8mm Hex) to a torque of 19 lb.ft. (25 N•m).
13. Remove the windshield header hardtop retaining bolts.
14. Carefully lift the rear of the hardtop and remove the locating pins from the left and right hand sides. Put the locating pins in the plastic stowage bag for future use.

NOTE

IT IS NOT NECESSARY TO COMPLETELY REMOVE THE HARDTOP FROM THE VEHICLE.

15. Re-install the left and right hand side hardtop retaining bolts and align bolts with the holes in the vehicle's body.

Article No. 91-20-2 Cont'd.

16. Hand tighten the side and rear retaining bolts through the spacer into the vehicle body.
17. Applying downward pressure to the front edge of the hardtop, tighten the windshield header bolts to a torque of 15-19 lb.ft. (20-25 N•m), Figure 9.
18. Tighten the rear retaining bolts with the installation tool then torque bolts to 10-16 lb.ft. (14-21 N•m).

CAUTION

CARE MUST BE TAKEN NOT TO STRIKE THE REAR WINDOW WITH THE INSTALLATION TOOL WHEN INSTALLING THE CENTER REAR RETAINING BOLT.

19. Inspect the hardtop fit.
 - a. Inspect fit of hardtop to header rail seal to ensure even contact.
 - b. Inspect fit of hardtop to division bar for even contact.

NOTE

ADJUSTMENT FOR INSPECTIONS A AND B MAY BE CARRIED OUT BY ALTERING THE HEIGHT OF THE HARDTOP AT RETAINING POINTS IN THE HEADER RAIL. THE PRIMARY CONCERN WHEN ADJUSTING THE HARDTOP IS TO ENSURE CORRECT FIT OF THE DIVISION BAR TO THE HARDTOP FRONT RAIL SEAL. THE SECONDARY CONCERN IS THE FIT ALONG THE HEADER RAIL SEAL, FIGURE 10.

20. Side rail sheet metal must be above 18°C (64°F) prior to application of weatherstrip.
 - a. Peel backing lines off weatherstrip by pulling on tags.
 - b. Press the weatherstrip against the side rail sheet metal by pressing thumb along the weatherstrip to seal, Figure 10.
21. Install 'B' Pillar trim covers and center trim button into right hand storage area underneath the right hand trim cover, Figure 12.

22. Connect the electrical lead to the hardtop connector. Feed the excess wire down into the storage compartment, Figure 11.
23. Install the trim covers, supplied loose in kit, over the hardtop rear retaining bolts, Figure 12. They are stored under the hardtop 'B' Pillar trim cover on the passenger side.
24. Gently ease heated backlite switch blanking plate from instrument panel, Figure 13.
25. Connect wiring, located behind previously removed blanking plate, to heated backlite switch and install switch, Figure 13.
26. Install and connect heated backlite relay, Figure 14.
27. Recheck door glass alignment to ensure correct sealing.
28. Put extra attaching hardware, trim covers and hardtop installation tool in plastic pouch in glove box for customer.
29. Water test vehicle to ensure correct sealing of the accessory hardtop.

SERVICE TOOLS REQUIRED

The service tools required are listed below.

- 8mm hex allen wrench
- 8 x 1.25 thread chaser or tap

PART NUMBER	PART NAME
FOJY-76500A06-A	Hardtop Service Kit

OTHER APPLICABLE ARTICLES: 90-25-7
WARRANTY STATUS: Eligible Under Basic Warranty Coverage

OPERATION	DESCRIPTION	TIME
912002A	Initial Fit Of Accessory Top	0.9 Hr.

DEALER CODING

BASIC PART NO.
7050196
OASIS CODES: 105000

CONDITION
CODE
35

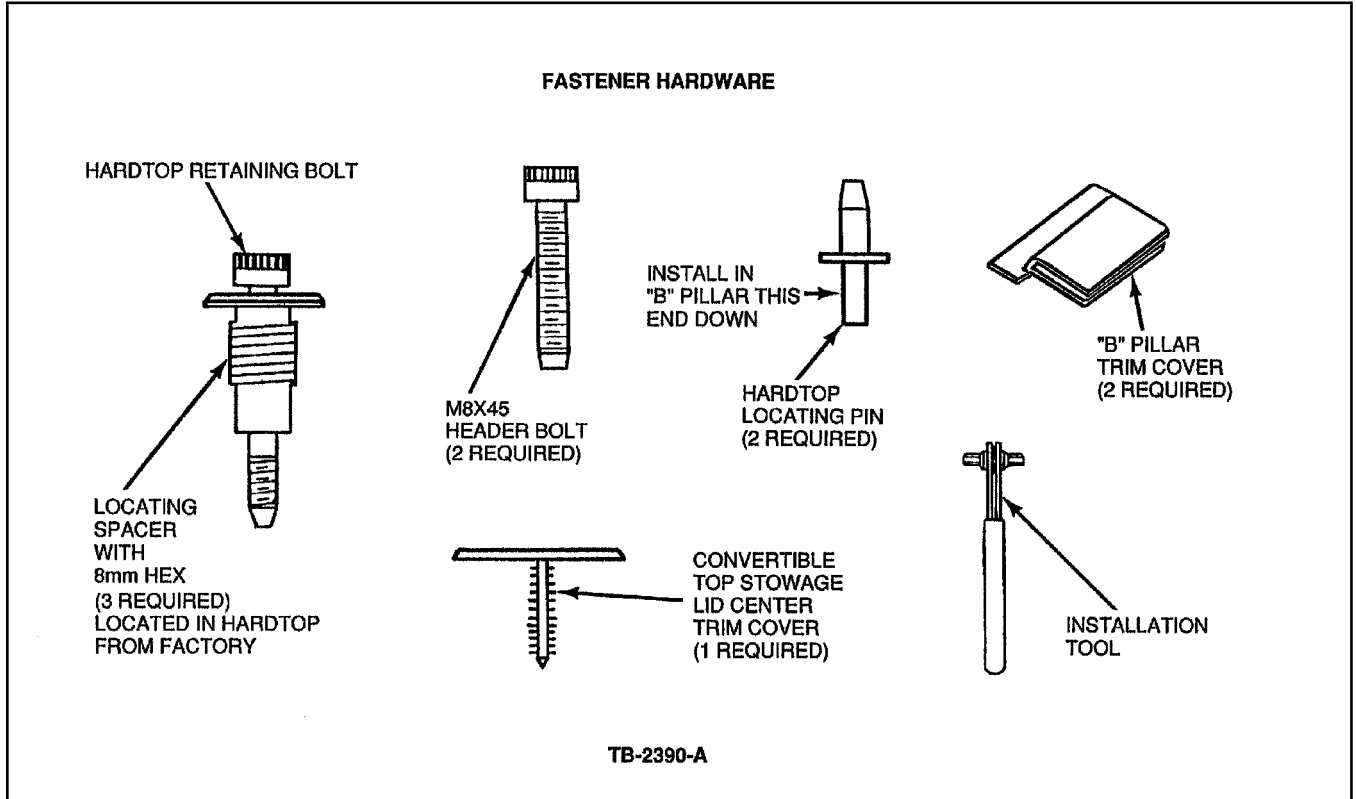

Figure 1 - Article 91-20-2

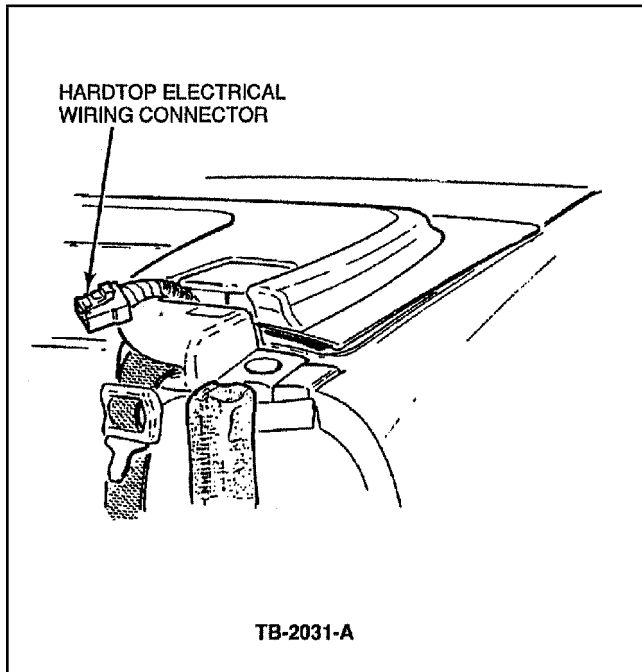

Figure 2 - Article 91-20-2

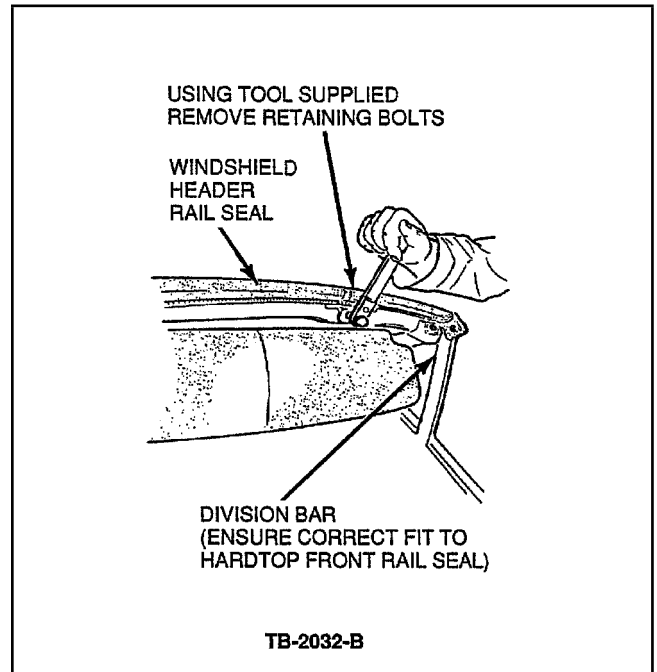

Figure 3 - Article 91-20-2

Article No. 91-20-2 Cont'd.

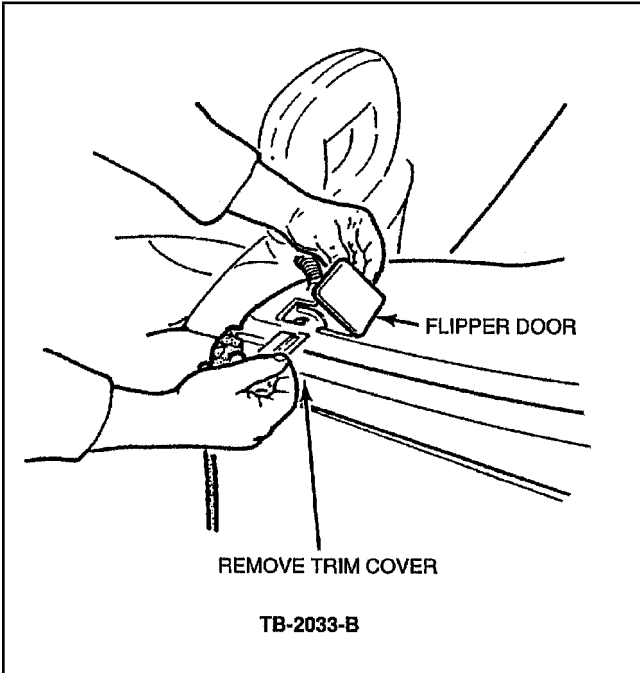

Figure 4 - Article 91-20-2

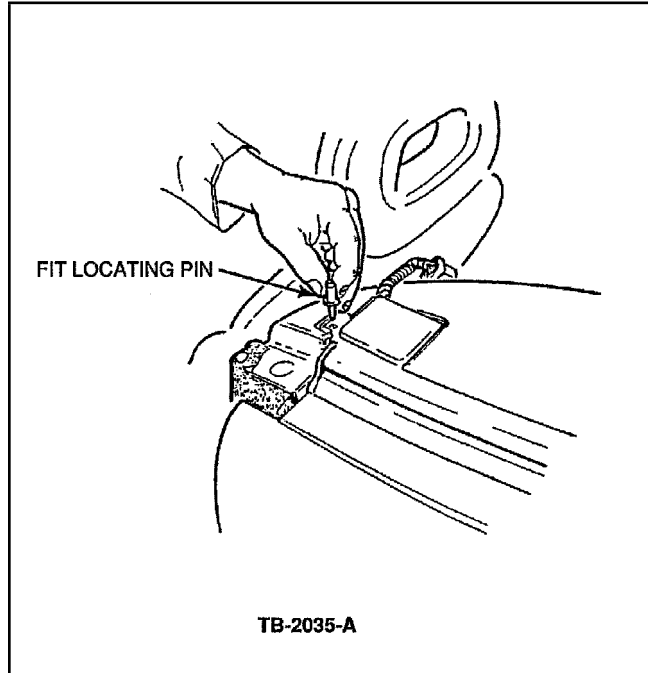

Figure 6 - Article 91-20-2

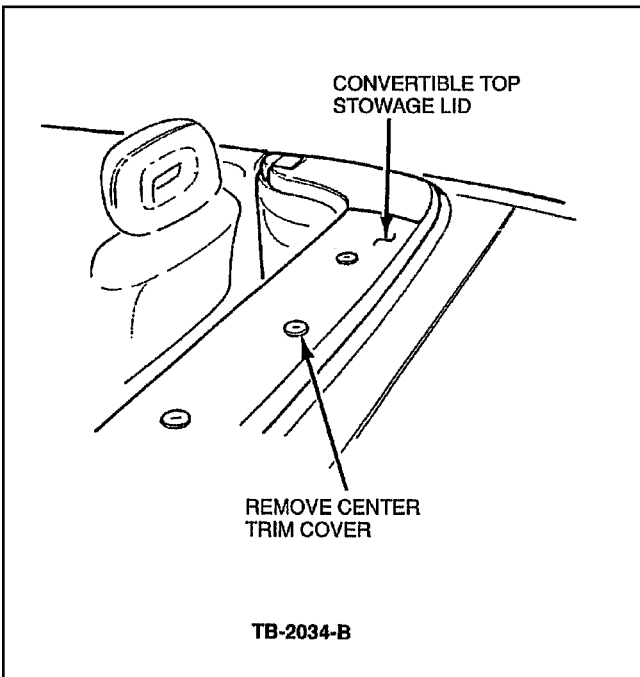

Figure 5 - Article 91-20-2

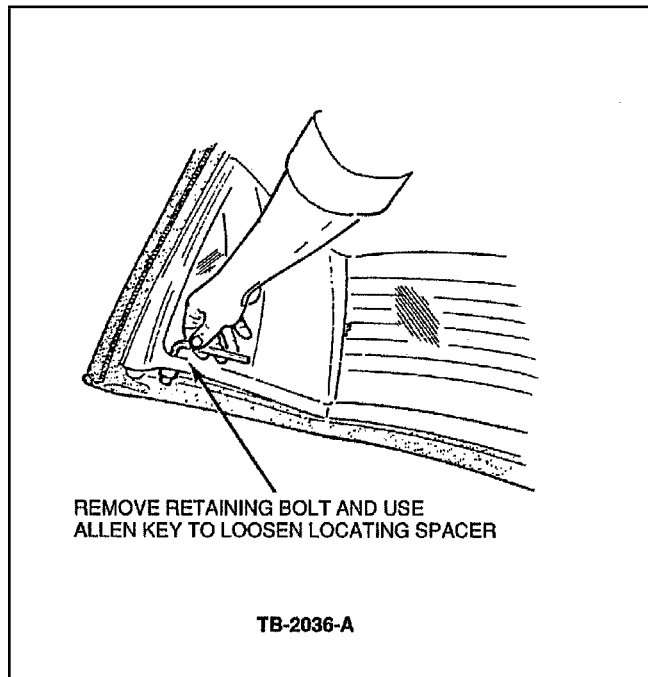

Figure 7 - Article 91-20-2

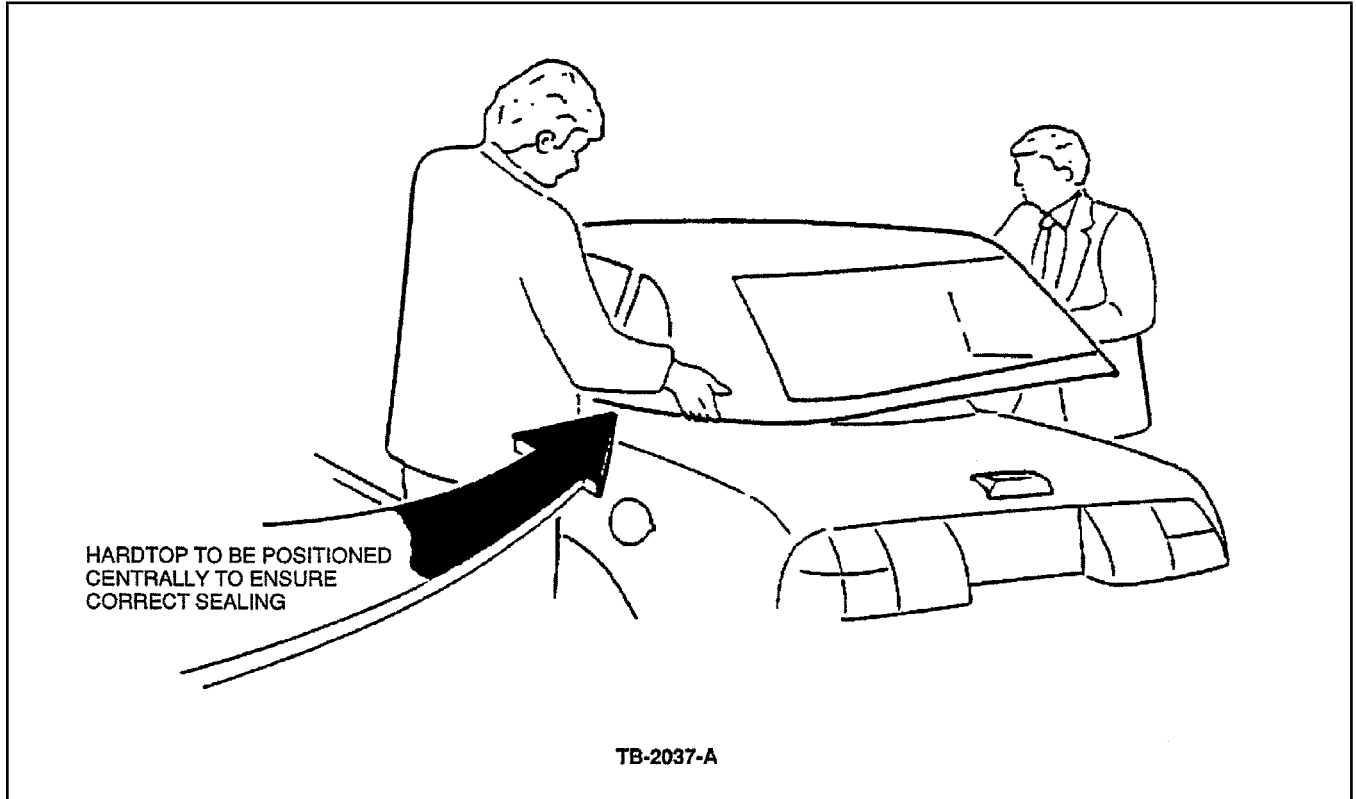

Figure 8 - Article 91-20-2

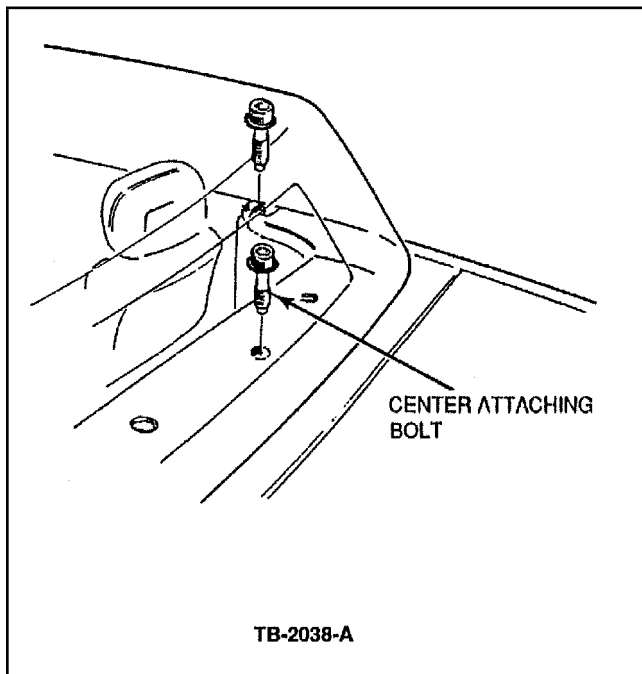

Figure 9 - Article 91-20-2

Article No. 91-20-2 Cont'd.

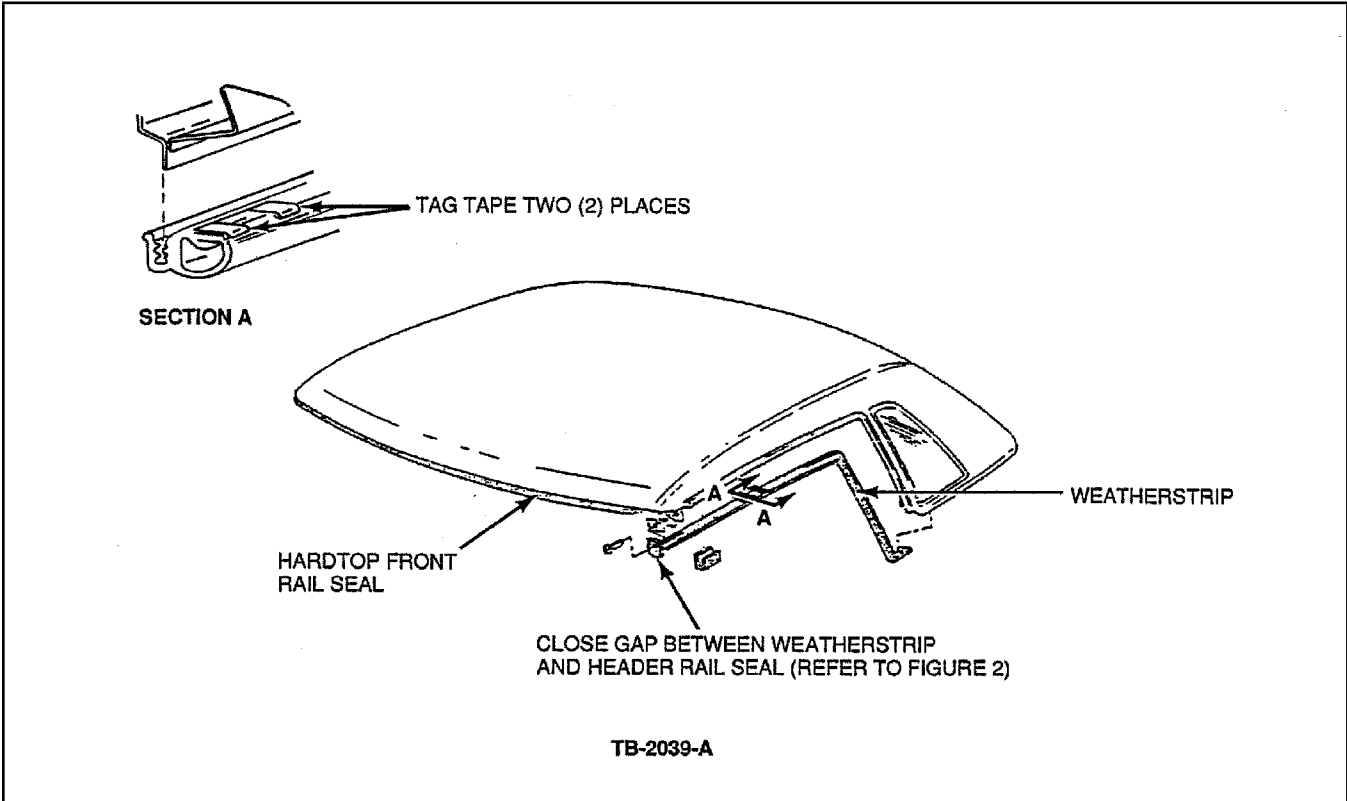

Figure 10 - Article 91-20-2

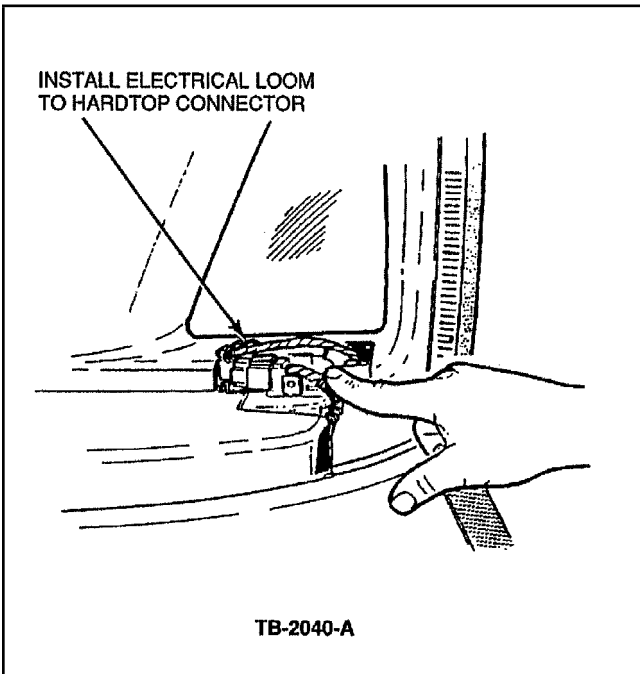

Figure 11 - Article 91-20-2

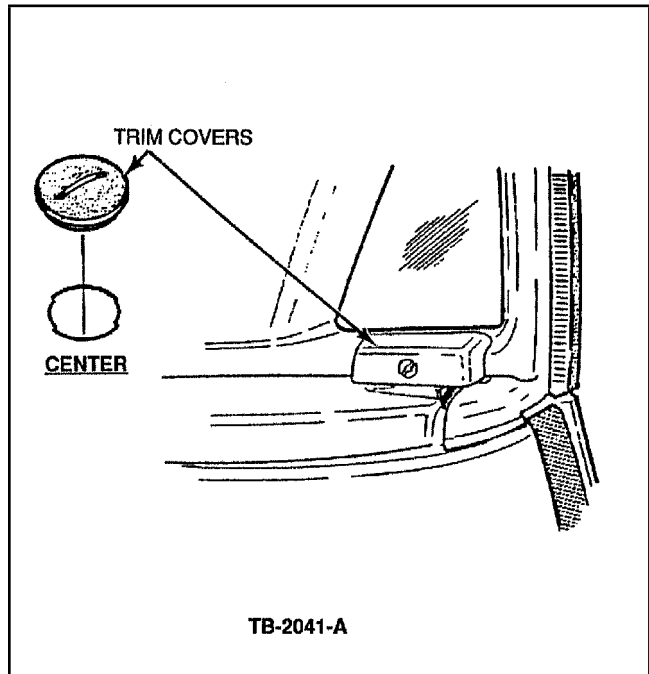

Figure 12 - Article 91-20-2

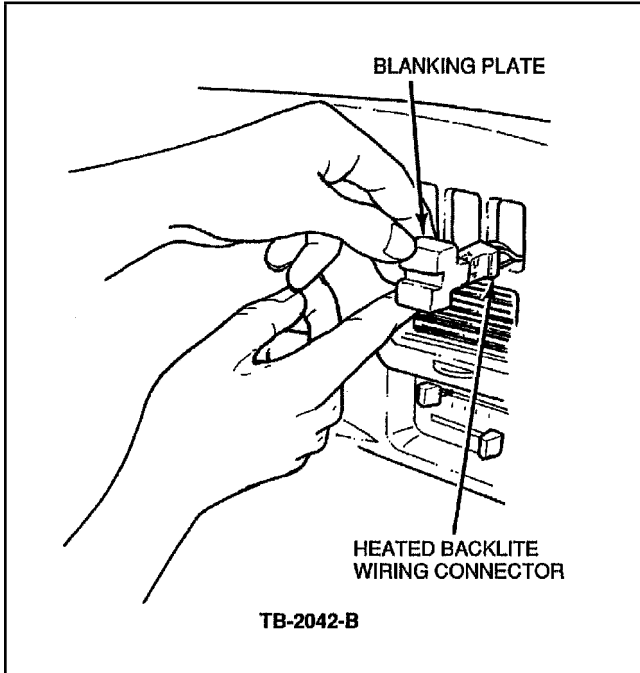

Figure 13 - Article 91-20-2

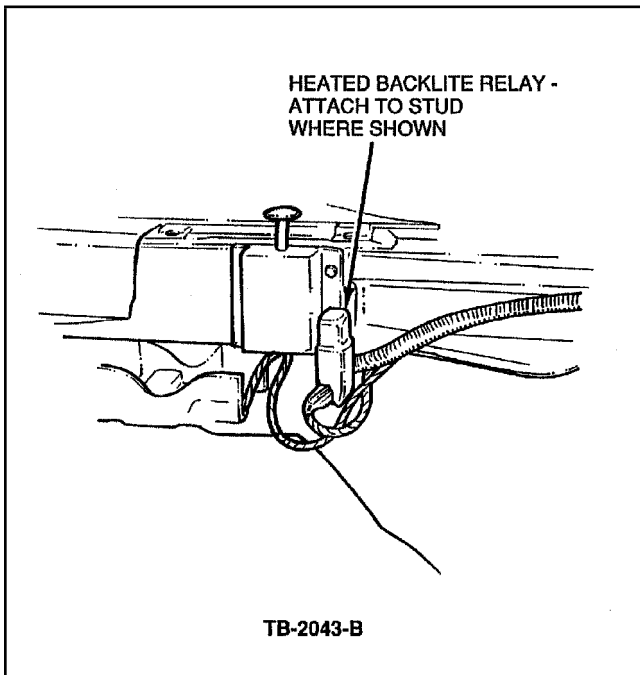

Figure 14 - Article 91-20-2